

PickToLight

Screw Removal Point for Manual Workstations
and Stationary Applications

DEPRAG
machines unlimited



Thanks to state-of-the-art technology, the intelligent PickToLight screw picking point optimizes your assembly processes, ensures greater ergonomics and improves product quality.

- **Time saving**
 - through precise provision of the fastener for the picking process
- **Reduction of incorrect assembly**
 - through targeted provision of the correct fastener
 - by extracting dirt particles - CleanFeed
- **Ergonomic working**
 - due to less space required at the pick point
 - through visual feedback as to which fastener is ready for picking

DEPRAG Feeding Technology

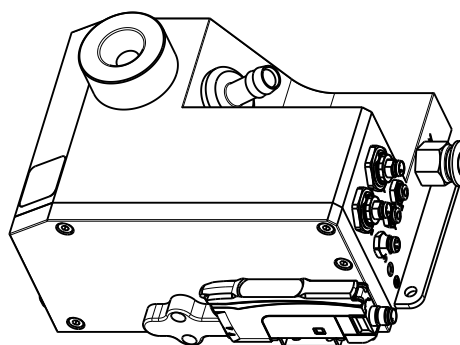
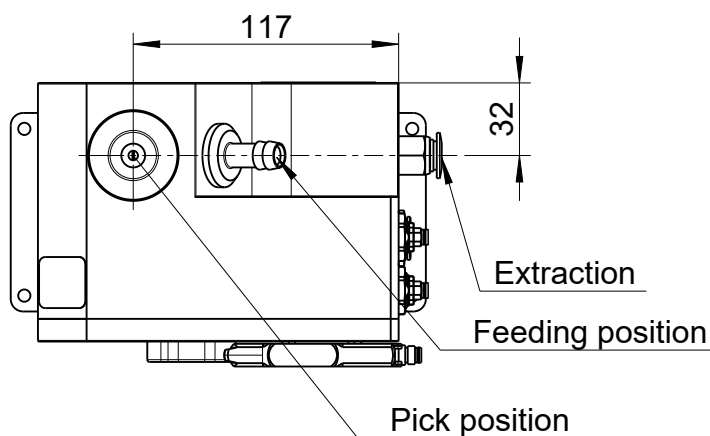
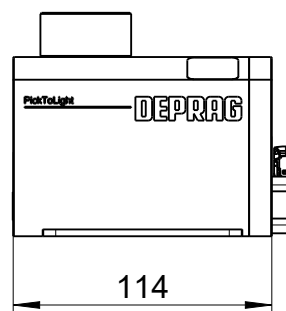
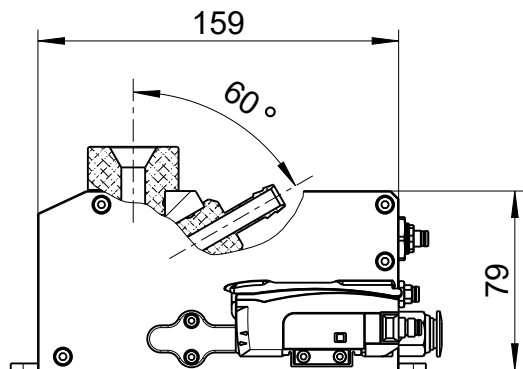

Dimensions in mm

P143481A

Technical data PickToLight

Type		PickToLight with work piece presence control PTL18...-LS	PickToLight without work piece presence control PTL18...-OLS
Max. total screw length (incl. head height)	mm/in.	50/1.95	50/1.95
Max. admissible head diameter	mm/in.	18/0.7	18/0.7
Voltage	V	24 Volt DC	24 Volt DC
Air pressure requirement, max.	bar/PSI	6/85.2	6/85.2
Dimensions (WxHxL)	mm/in.	125x70x159 / 4.9x2.7x6.2	114x70x159 / 4.45x2.7x6.2
Weight	kg/lbs	2.6 / 5.72	2.5 / 5.5
Ambient temperatur range		-10 °C to +55 °C	

Optional Accessories

Vacuum injector for extraction	Part no.	917305C
Filter for extraction	Part no.	109092C
Push-in fitting for extraction	Part no.	826941